

INSTALLATION GUIDE

STABILIZING MAGNET FOR TALL DRAWER FRONTS

INTRO

INSTALL STABILIZING MAGNETS ON YOUR TALL DRAWER FRONTS
TO MAKE SURE YOUR DRAWER FRONTS ARE STABLE

INCLUDED IN THE PACKAGE

2X MAGNET
2X WOOD SCREW, $\varnothing 4, 2 \times 16 \text{MM}$

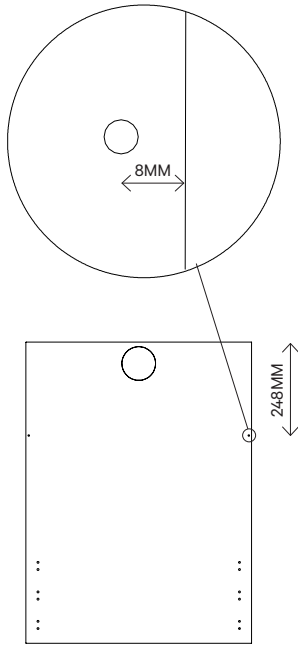

1

MARK THE POSITION OF THE DRILLINGS ON THE BACK SIDE OF THE DRAWER FRONT.
DRILL 12MM DEEP HOLES USING A 2MM DRILL BIT

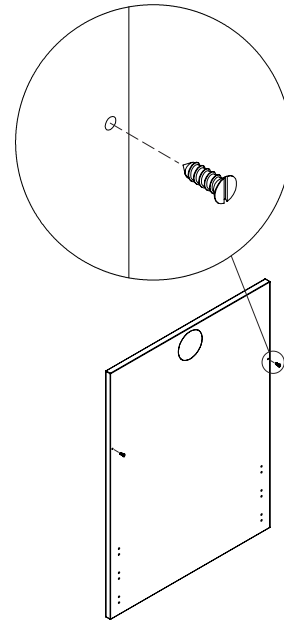

2

FASTEN THE WOOD SCREWS INTO THE PREDRILLED HOLES.
THE SCREW HEAD MUST NOT PENETRATE FURTHER THAN
THE SURFACE OF THE DRAWER FRONT

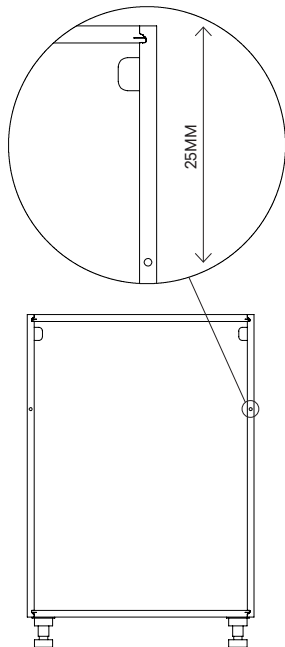

3

MARK THE DRILLING POSITIONS AS SHOWN ABOVE. DRILL 13MM DEEP HOLES
USING A 8MM DRILL BIT. MAKE SURE THE HOLES ARE CENTERED BETWEEN THE EDGES
OF THE CABINET SIDES

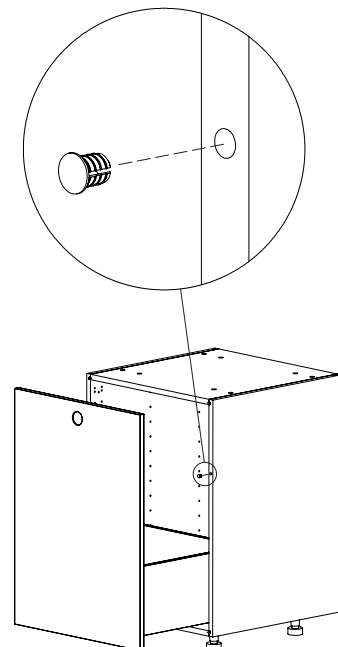

4

PRESS IN THE MAGNET.

YOU ARE DONE!