

INTRO

When connecting fronts of the REFLECT design (besides the standard front connector package) additional distancing washers are needed.

This is what you need (items not to scale):

- 2x Front Connector
- 8x REFLECT Distance Washer
- 8x Chipboard Screws



FRONT CONNECTOR



REFLECT DISTANCE WASHER
UNI-P-ACC03-MIS012



CHIPBOARD SCREWS
UNI-P-ACC03-MIS009

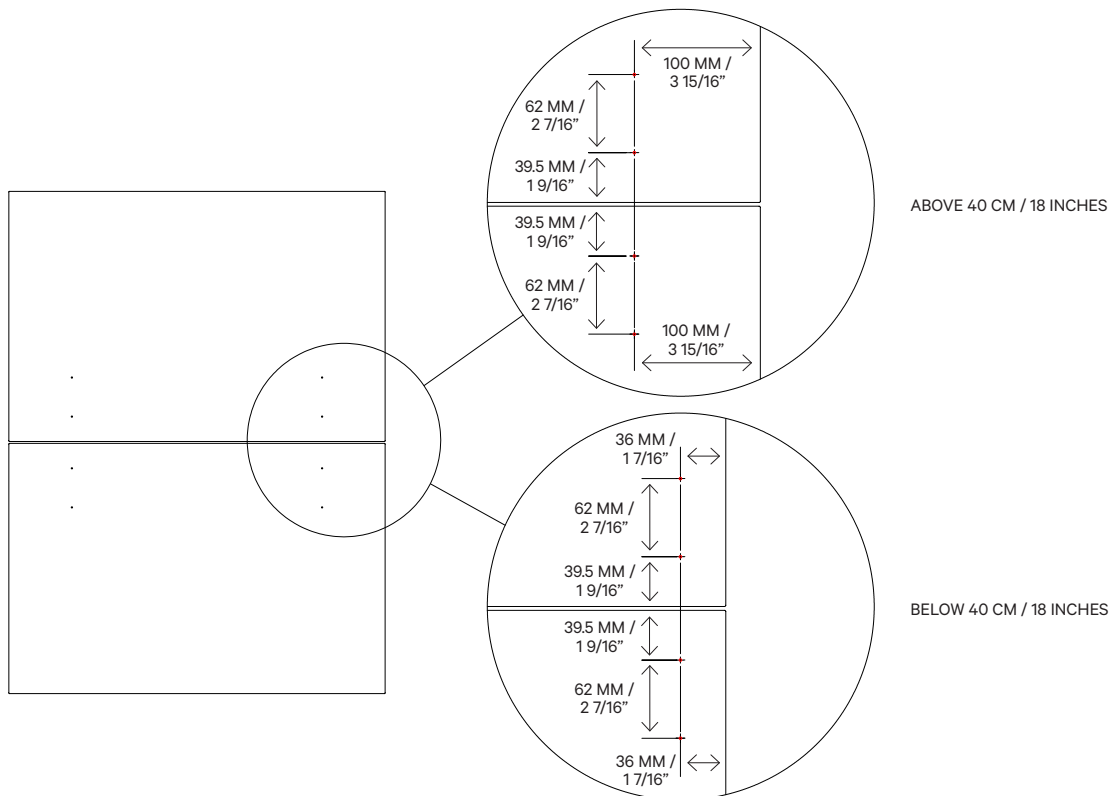

1

MEASURE AND MARK THE POSITION OF THE SCREWS DEPENDING ON THE WIDTH OF YOUR FRONTS.

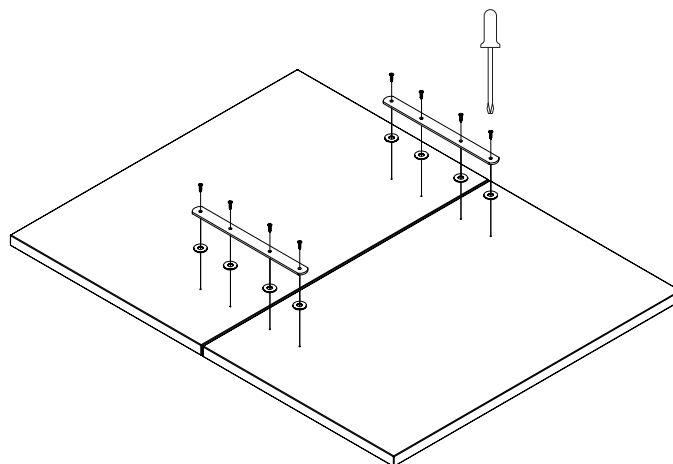

2

FASTEN THE FRONT CONNECTOR ONTO THE FRONTS WITH SCREWS. THE REFLECT DISTANCE
WASHERS SHOULD BE PLACED BETWEEN THE FRONT AND THE FRONT CONNECTOR.

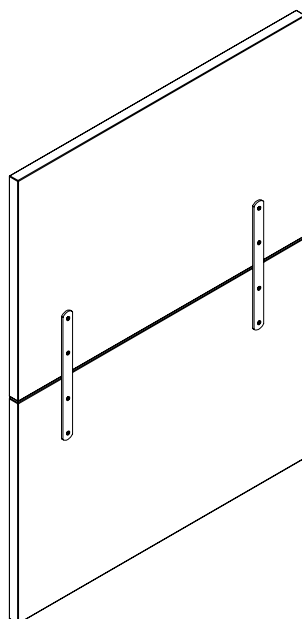

3

FINISHED PRODUCT
